

SAE ARIZONA • NEVADA SECTION

February 2008

MEETING: FEB 21

Section Web Site: www.saearizona.org - Sign up for your newsletter on our website.

HIGHLIGHTS...

- General Dynamics: Tactical Decisions
- Message from the Chair

- Recap of January Meeting

- A World in Motion
- Map to Meeting

Dinner Presentation...

General Dynamics: Tactical Decisions by John Capulli Jr.

Engineering approach to planning for and executing a difficult physical task. Hitting a baseball going 95 mph has been described by some as the most difficult task to do in sport. Attacked as part of the DOD OODA cycle, - observe, orient, decide and act, which is applicable to military and intelligence operations and can be applied to any activity that requires observation, planning, training and execution. From a baseball perspective, the basic references used are Ted Williams and Charlie Lau's books on hitting a baseball along with 30 years of baseball experience from high school, through college, and semi-professional. The subtitle is "for those without super-human abilities", which shows how a normal human being can perform this activity.

JOHN CAPULLI JR.

John has been on active duty, for 8 years, in the Air Force in Weapons and Satellite systems and 18 years in the Air Force Reserves in satellite engineering, civil engineering, emergency management and Intelligence. He worked in Satellite Power Systems Engineering and Satellite Systems Engineering at Lockheed, Hughes, and TRW before joining Motorola to work on Iridium. On Iridium he worked on Space Segment, Systems Engineering and Operations. While working at Motorola Government group and at GD, John worked on numerous satellite control system jobs as Project Lead. He was a DOD interface for Military Iridium users. More recently, he was responsible for technical execution of MUOS demos with Ericsson CN and RAN with DOD PS and CS encryption and connection to Navy Secure Servers. His present position is Project Lead on GOES-R Control Segment program, which is in the pre RFP phase.



Courtesy of hoststoveandbeyond.mlblogs.com

Message from the Chair

What a great way to start the New Year for our SAE section! That was the reaction of our members and guests who attended the January 17th meeting. General Motors sent three of their Chief Engineers who were in charge of the new hybrid Tahoe full-size truck to present the details on this vehicle. The date of our meeting happened to coincide with the production release of these new vehicles to the public from the Arlington assembly plant. This is an amazing vehicle with many technological developments. Perhaps just as exciting was the organizational approach taken to develop this and other General Motors hybrid vehicles. The entire engineering team is co-located in one building at the General Motors Proving Ground in Milford Michigan. This building provided engineering office space, supporting laboratory space, and vehicle shop area. In addition, the entire GM Proving

DATE	TIME	LOCATION	COST With Dinner	Presentation Only	
Feb 21	Social	- 6:00 pm	Hilton Phoenix Airport	Members - \$22	\$10
	Dinner	- 6:30 pm	2435 S. 47th St, Phoenix-85034	Guests - \$27	\$10
	Presentation	- 7:30 pm	480.894.1600	Students - \$10	no charge
RSVP by 10:00am Tuesday Feb 19.			Call Sam Bethune: 602.364.7456		

Grounds road system was located just outside the building door. The net result was the development of an all new hybrid vehicle in a three year timeframe. General Motors also provided two Super Bowl Hybrid Tahoes that were on display at the hotel entrance for members to examine in detail. Over 65 people attended our meeting. Thank you to Larry Wilson our treasurer for handling this large group.



Also at our meeting, a presentation was made by two students from ASU who represented the SAE BAJA -12 member project team. This is a yearlong project to design and build an off road vehicle and participate in an intercollegiate competition to be held May 31 at the Caterpillar Proving Grounds in Peoria, Illinois. Designing and building the SAE BAJA vehicle provides an opportunity for college students to apply the academic learning to a real world product design. Hands on experience in bringing a product to production provides training in solving problems and creating manufacturable designs. The students requested support from our members and guests. I would like to challenge our members to support this team with your individual/corporation contributions. This is truly a “a pass-it-forward” type of giving. All of us have benefited with financial help during our engineering education and this is a chance for you to give back. By the way, all contributions are tax deductible through the ASU foundation.

Two of our members have received special recognition from SAE International this year. Robert Riley, who has been our newsletter editor for many years, received

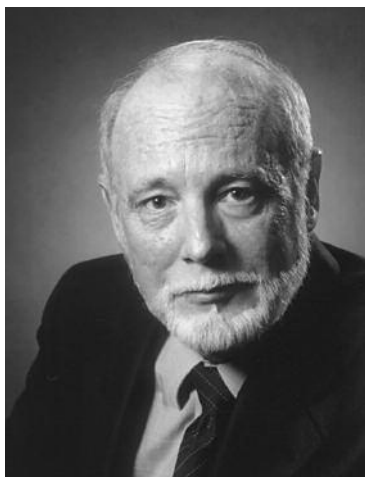

Robert Riley
Distinguished Section Member

the Distinguished Section Member award. Dave Vasquez, who was past chair, webmaster and historian, received the Distinguished Young Member award. Both Bob and Dave will be attending a special reception this April at the SAE International annual convention in Detroit. Congratulations to Dave and Bob.

Our next meeting, February 21 will feature a



Dave Vasquez
Distinguished Young Member

presentation from General Dynamics. For March, Honeywell will be our speaker. Our section is fortunate that we can have speakers from both automotive and aerospace.

Please let me know if you have any suggestions for future programs or improvements in our meetings.

Bill Gest, Section Chair

Recap of January Meeting

by Joshua Rudin

COFFEE TALK: ASU SAE BAJA CAR

The ASU SAE chapter has 12 students who design, manufacture and test a single seat ATV. There are 3 teams which are divided by chassis & suspension, powertrain and controls.

Chassis metal is 4130 chromoly, engine is a 10 HP unmodified Briggs & Stratton and suspension is designed to withstand a 10" travel for off-road capabilities.

This vehicle will be competing in Illinois in May with a series of dynamic and static events. ASU SAE is looking for

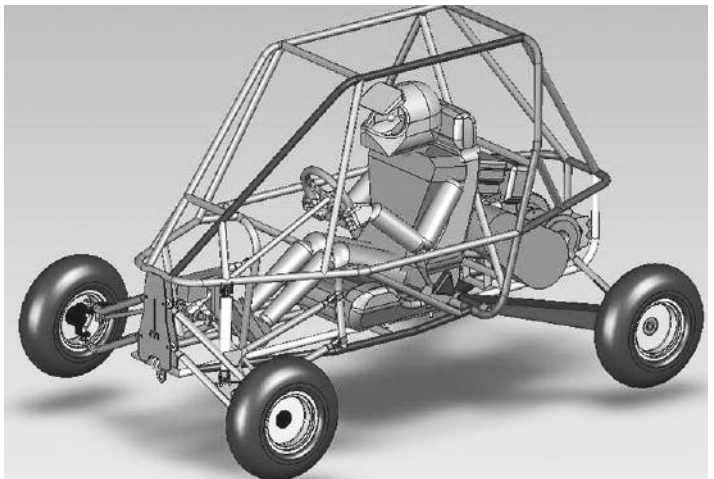

Baja Vehicle

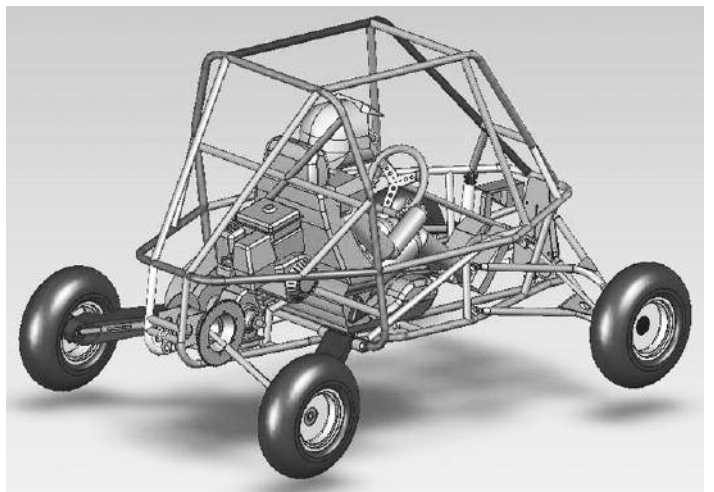

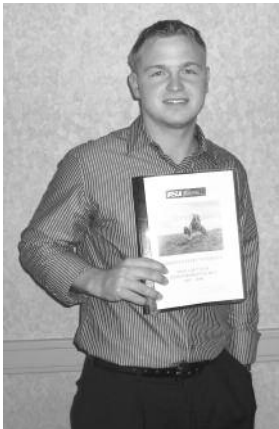

Tyler Girtman

donors who can contribute to the team's expenses. Sponsorship packets which explain in detail the competition, the benefits for the students & sponsors, and the sponsorship tier can be given to anyone who is interested in contributing. For more information, contact Tyler Girtman at TylerG@climatec.com or Darren Gest at drn@cox.net.

GM TAHOE HYBRID

Mr. Cieslak began the presentation saying there will be 1.1 billion vehicles in 2020 and that a change in "old DNA" of internal combustion/fossil fuels would have to be changed to "new DNA" of electricity, in spite of the fact that emissions have been reduced by 99% over time.

The GM Tahoe hybrid design uses a "vehicle energy breakdown" in which energy losses are categorized into heat and mechanical subsystems. Overall fuel economy is an integral of the sum of aerodynamics, mass, vehicle technology and driver interface.



Left to Right: Mark Cieslak, Tim Grewe, Scott Miller, and Bill Gest

Aerodynamics present the most significant energy loss. The body structure of the GM Tahoe hybrid is designed to minimize drag much more acutely than a

conventional unit.

The GM Tahoe hybrid adds 400 lbs of mass but is offset by reductions in the hood and seats using premium materials.

In addition a ESS or Energy Storage System is used to auto start/stop engine the 6.0 Liter displacement down to 3.0 L. A CVT or continuous variable transmission stores mechanical energy as well, as well as the braking system which uses electronic, regenerative brake-by-wire system to capture frictional losses and recharge the battery. Driver interface controls are presented on a screen, as is a continuous fuel mileage indicator.

Hybrid Technology is attained by placing a 330V battery pack under the second seat. This battery pack is warranted through the entire life of the vehicle (8 yrs, 100K miles).

One unique aspect of this full size vehicle is that it can run strictly as an electric car or have the capability to tow & haul as a typical SUV owner would expect.

This vehicle has been tested for cold weather, hot weather, NVH, HVAC, dynamics, altitude and humidity. A hybrid integration triangle is utilized among the 425 engineers

in this project to ensure quality. The GM Tahoe hybrid uses a high level of system level integration to achieve these high levels of efficiency using actuators operating at 100 milliseconds or faster.

We commend the efforts of these engineers and wish them success in this new vehicle.

A World in Motion - In Arizona

by Don Robins

Angela Kirschner, a 7th science grade teacher at Western Peaks School in Surprise was awarded the Gary Dickenson Award by SAE for her involvement in the AWIM program here in Arizona. She was the only middle school teacher to receive this recognition by SAE for the 2007 school year. She received a nice framed copy of the award and \$2,000 from SAE, to be shared equally with her school. In 2008, the AWIM program sponsored by SAE and the General Motors Retiree Club of Arizona will add one more school in the Phoenix area, and the GM Retirees in Tucson are planning on starting an AWIM program with one school in Tucson. Last year we impacted 282 students in 2 schools, this year we should have 4 schools and impact about 380 students. The 7 week program will be starting the week of January 21 at most schools. however, we are also working with teachers in Mesa and Chandler who are interested in starting AWIM programs in their school.

AWIM brings math and science principles to life through highly interactive learning experiences that incorporate the laws of physics, motion, flight, and electronics. The curriculum joins teachers, students, and engineers in exploring physical science. The program is designed for students in grades 4 - 10. For more information, go to www.awim.org or call Don Robins @ 248.807.3604.

*** Meeting Location ***

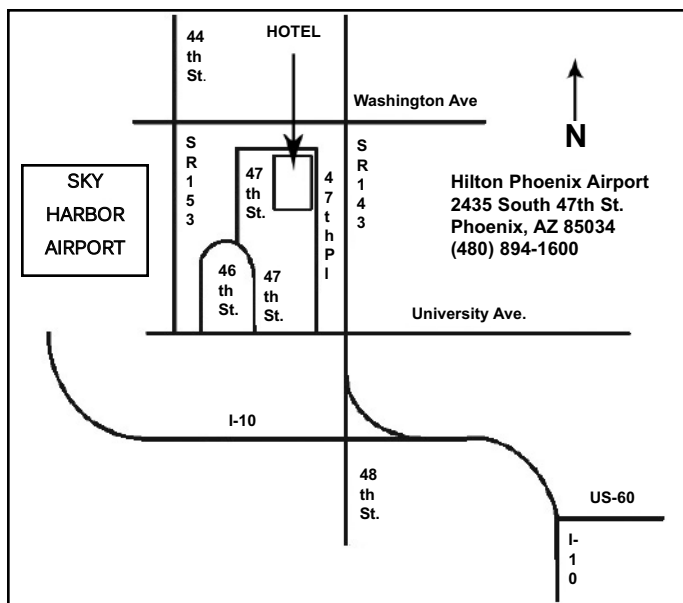

THE UNIVERSITY OF ARIZONA ANNOUNCES:

The 45th Reliability Engineering and Management Institute provides all engineers, particularly Reliability Managers and Engineers, Product Assurance Managers and Engineers in government and Industry, with a working knowledge of Reliability Engineering Theory and Practice, Mechanical Reliability Prediction, Reliability Testing and Demonstration, and more. Dr. Dimitri B. Kececioğlu and 10 speakers from 15 sponsoring industries will take part in expertly covering the subject matter of this Institute. For more information, please see the contact information below.

The 34th Annual Reliability Testing Institute provides coverage of how to implement and manage the Design-for-Reliability process through testing, to implement an integrated Reliability & Maintainability Engineering management strategy, learn a practical approach to attain the high Reliability goals demanded nowadays, to improve our worldwide competitive posture by creating more Reliable products through thorough testing, to determine the useful life of our products, and more. Dr. Dimitri B. Kececioğlu and 10 speakers from 10 sponsoring industries will take part in expertly covering the subject matter of this Institute. For more information, please see the contact information below.

THE 45th ANNUAL RELIABILITY ENGINEERING
AND MANAGEMENT INSTITUTE
November 12-15, 2007

THE 34th ANNUAL APPLIED RELIABILITY TESTING INSTITUTE
May 5-8, 2008

Clarion Hotel, Tucson Airport
6801 S. Tucson Blvd.
Tucson, Arizona 85706
520-746-3932 or 800-526-0550

Registration Fee: \$1500 Proceedings Cost: \$50

For Details and Technical Information, please write to:
Dr. Dimitri B. Kececioğlu, P.E.
Professor of Aerospace and Mechanical Engineering
The University of Arizona
1130 N. Mountain Avenue, Bldg. 119, Room N517
P.O. Box 210119, Tucson, AZ 85721-0119
You can also Call: 520-621-6120, Fax: 520-621-8191,
Or Email: dimitri@u.arizona.edu
Please see his website at: <http://www.u.arizona.edu/~dimitri>



ESG Engineering (WWW.ESGENG.COM) is a full service mechanical engineering consulting company located in Tempe, Arizona. We provide Industrial Design, CAD Design and Engineering Analysis including linear and non-linear Stress, Dynamics, Fluids, Thermal and Tolerance. We also sell the Z Corp rapid prototyping machines and scanners; SensAble design software and the full line of Altair HyperWorks analysis software. How can we help you? Contact Bill Gest at 602-618-1304.

ESG Engineering is growing, contact Mike Kremer at MKremer@esgeng.com for career opportunities.

**ARIZONA-NEVADA SECTION:
Meeting Schedule**

Feb 21 - General Dynamics - Tactical Decisions
Mar 20 - Honeywell
Apr 17 - Empire-Caterpillar Trimble

Bill Gest
Chair
bgest@esgeng.com

Joshua Rudin
Vice Chair
602-369-6487

Mike Kremer
Secretary
MKremer@esgeng.com

Larry Wilson
Treasurer
wilson.lawrence@orbital.com

Robert Riley
Newsletter Editor
623-872-8010



Society of Automotive Engineers
Arizona Section
69 West Wilshire Drive
Phoenix, AZ 85003

Non-Profit Org.
U.S. POSTAGE
PAID
Phoenix, AZ.
Permit No. 1571

POSTMASTER: DATED MATERIAL - PLEASE DELIVER PROMPTLY - THANK YOU!